

Characteristics / Ordering Code

Parker electronic modules PID00A-40* for rail mounting are compact, easy to install and provide time-saving wiring by disconnectable terminals. The digital design of the circuit results in good accuracy and optimal adaption for closed loop controls by a comfortable interface program.

Features

The described electronic unit combines all necessary functions for the optimal operation of closed loop controls. The most important features are:

- Extended PID controls
- Speed control with position feedback
- Differential input stage with different signal options
- Output stage with different output options
- Four-quadrant ramp function
- Status indicator
- Digital circuit design
- Parametering by USB interface
- Connection by disconnectable terminals
- Compatible to the relevant European EMC standards
- Optional technology function "linearization"
- Comfortable PC user software, free of charge:
www.parker.com/isde - see "Support", or directly at
www.parker.com/propxd.

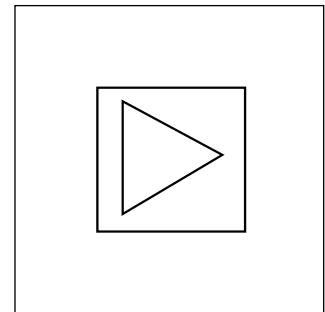
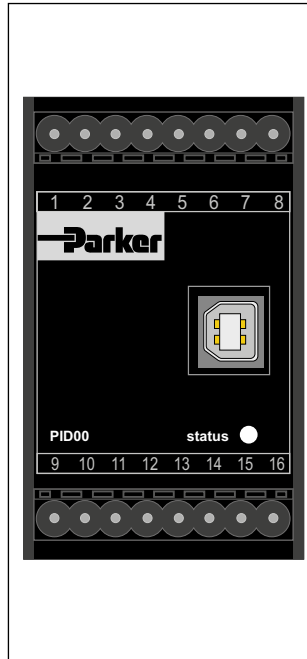

Ordering code

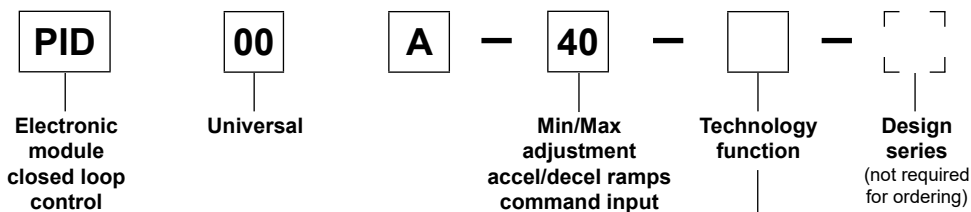

Code	Function
0	Standard
1	Linearization option

11

Technical data

General		
Model		Module package for snap-on mounting on EN 50022 rail
Package material		Polycarbonate
Inflammability class		V0 acc. UL 94
Installation position		unrestricted
Ambient temperature range	[°C]	-20...+60
Protection class		IP 20 acc. EN 60529
MTTF _D value	[years]	150
Weight	[g]	160
Electrical		
Duty ratio	[%]	100
Supply voltage	[VDC]	18...30, ripple < 5 % eff., surge free
Current consumption max.	[mA]	100
Pre-fusing	[mA]	500
Command signal options	[V] [mA] [mA]	+10...0...-10, ripple <0.01 % eff., surge free, Ri = 100 kOhm +20...0...-20, ripple <0.01 % eff., surge free, Ri = <250 Ohm 4...12...20, ripple <0.01 % eff., surge free, Ri = <250 Ohm <3.6 mA = solenoid output off, >3.8 mA = solenoid output on (acc. NAMUR NE43)
Input signal resolution	[%]	0.025
Differential input voltage max.	[V]	30 for terminals 5 und 6 against PE (terminal 8)
Enable signal	[V]	0...1: Off / 5...30: On / Ri = 100 kOhm
Status signal	[V]	0...0.5: Off / Us: On / rated max. 15 mA
Monitor signal	[V]	+10...0...-10, rated max. 5 mA, signal resolution 0.4 %
Output signal options	[V] [mA] [mA] [mA]	+10...0...-10, rated max. 15 mA +20...0...-20, Ro < 500 Ohm +50...0...-50, Ro < 200 Ohm 4...12...20, Ro < 500 Ohm
Output signal resolution	[%]	0.025
Potentiometer supply	[V]	+10...0...-10 2 %, rated max. 15 mA
Sensor supply	[V]	18...30 (Us), rated max. 100 mA
Adjustment ranges	Min [%] Max [%] Ramp [s] Zero offset [%]	0...50 50...100 0...32.5 +100...-100
Interface		USB type B
EMC		EN IEC 61000-6-2, EN IEC 61000-6-4
Connection		Screw terminals 0.2...2.5 mm ² , disconnectable
Cable specification	[mm ²]	0.5 overall braid shield (AWG20)
Cable length	[m]	50
Options		
Technology function	Code1	Software adjustable transfer function with 10 compensation points for linearization of valve behaviour

Dimensions

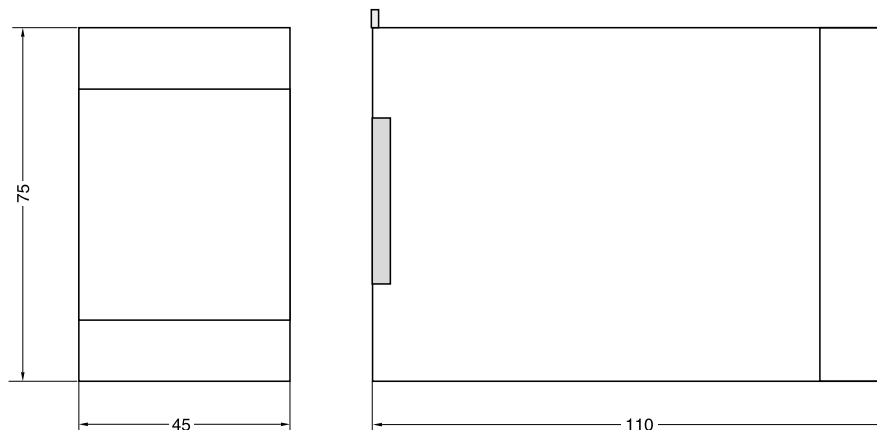

PID00 UK.indd 23.06.22

Block Diagram / Construction

Block diagram

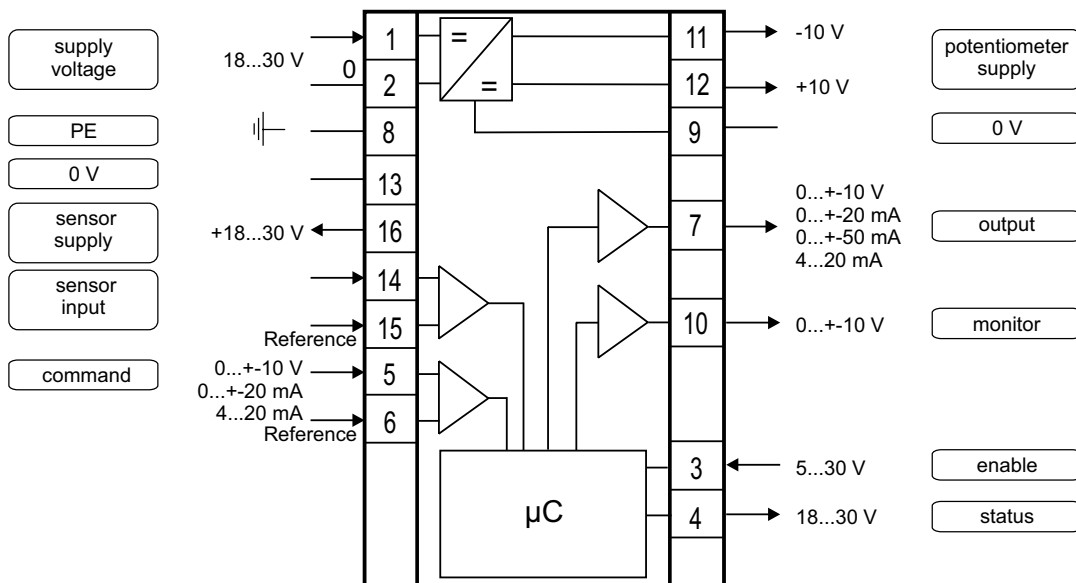

Signal flow diagram

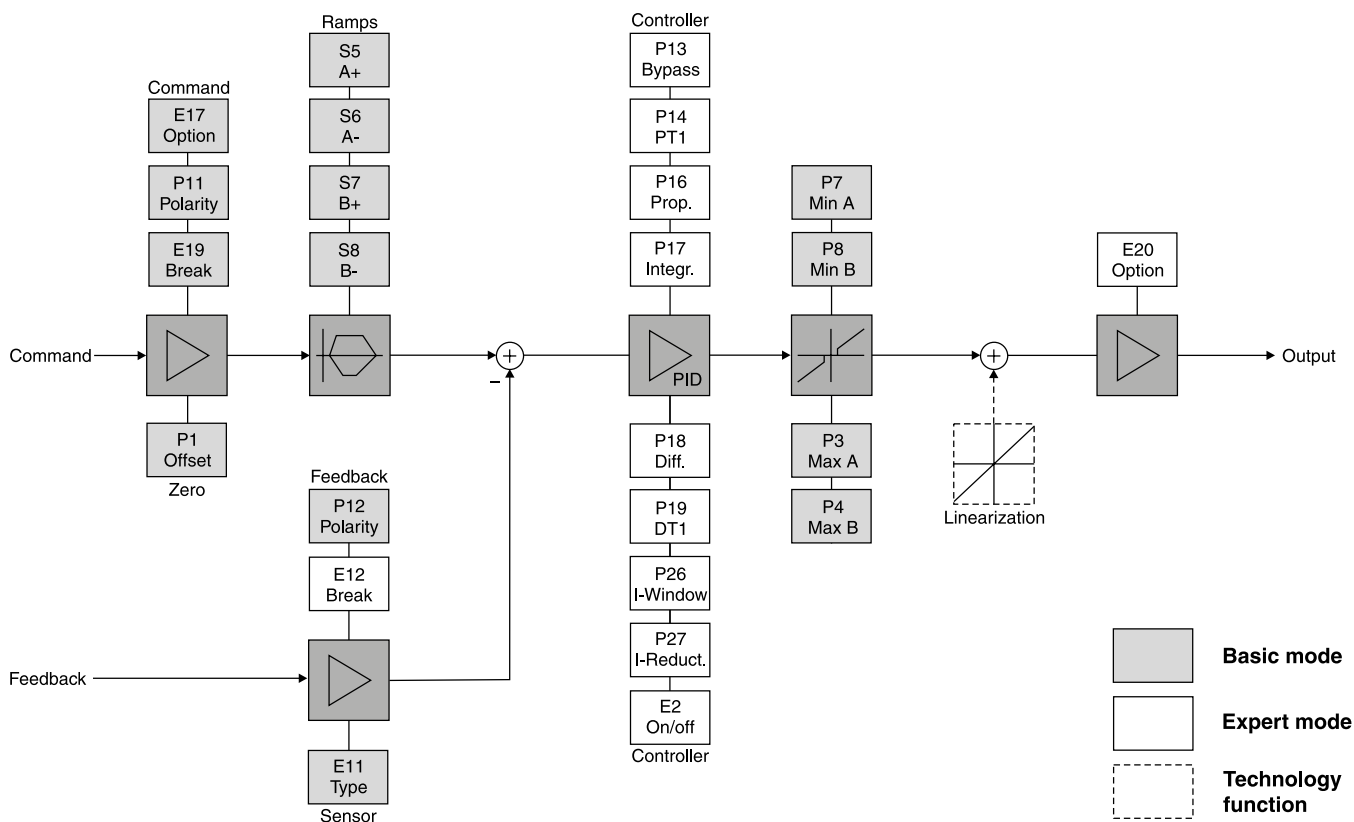

11

Basic mode
 Expert mode
 Technology function



ProPxD interface program

The ProPxD software permits comfortable parameter setting for the module electronics. Via the clearly arranged entry mask the parameters can be monitored and modified. Storage of complete parameter sets is possible as well as printout or record as a text file for further documentation. Stored parameter sets may be loaded anytime and transmitted to other valves. Inside the electronics a nonvolatile memory stores the data with the option for recalling or modification.

The PC software can be downloaded free of charge at www.parker.com/propxd.

Features

- Comfortable editing of all parameters
- Depiction and documentation of parameter sets
- Storage and loading of optimized parameter adjustments
- Executable with all actual Windows® operating systems from Windows® XP upwards
- Plain communication between PC and electronics via USB interface

